

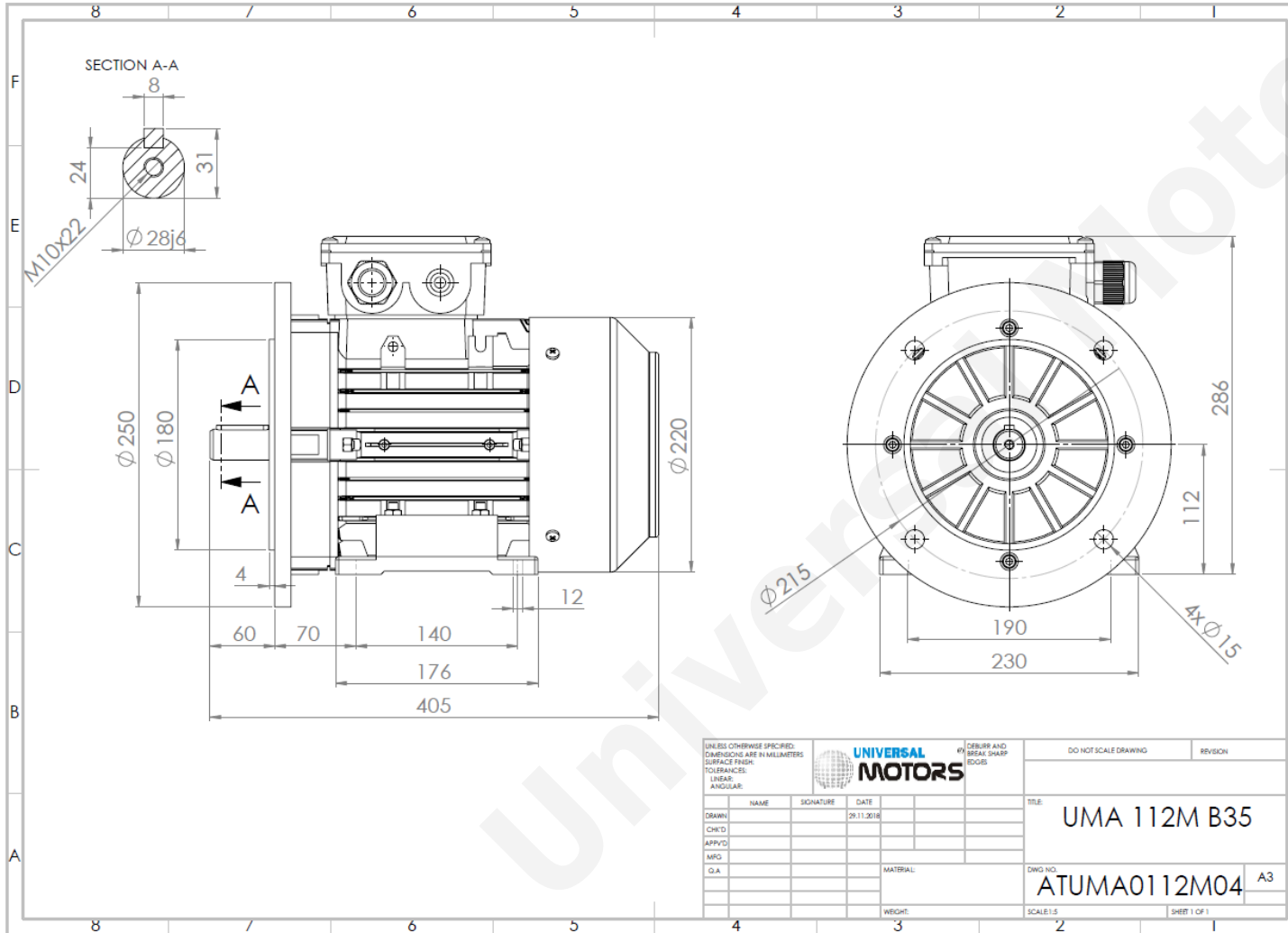

TECHNICAL DATA

Three Phase Electric Motors - Aluminum Frame
 UM3A 112M2 2 IE3
 5.5 kW / 7.5 Cv
 RPM



Motor type:	UM3A 112M2 2 IE3
Output:	5.5 kW / 7.5 Cv
Frequency:	50 Hz
Voltage:	400 V
Current:	9.78 A
Power factor (Cos Ø):	0.91
Poles:	2
Insulation class:	F
Temperature rise Class:	B
Efficiency 50%:	89.1 %
Efficiency 75%:	89.6 %
Efficiency 100%:	89.2 %
Torque:	18.0 N.m
Tstarting/Tnominal:	3.3
Istarting/Inominal:	11.9
Tmaximum/Tnominal:	4.2
Noise:	78 Db(A)
Weight:	35.7 Kg
Brake AC:	AC6
Torque Brake DC:	60 N.m
Bearing DE:	6306 2Z
Bearing NDE:	6206 2Z
Torque Brake AC:	60 N.m
Brake DC:	REB-05-14

Regime - S1

Altitude - 1000m

Environment Temperature - 40°C

CONTACTS:

UNIVERSAL MOTORS Tel: +351 252 299 080
 Rua de São Brás,745 Fax: +351 252 299 089
 4480-782 VILA DO CONDE Mail: geral@universalmotors.pt

* References applied only in the UK